

# Product Information Solenoid Diaphragm Dosing Pump MAGDOS LB

## Reliable dosing of chemicals

Solenoid-driven diaphragm dosing pumps play an important role in the reliable and accurate dosing of liquids in the process cycles. They are appropriate for low-pressure applications and small dosing quantities.

Dosing pumps are used in many branches of industry that work with liquid chemicals - not excluding toxic and aggressive media.

## The good-value alternative

The MAGDOS LB solenoid diaphragm dosing pump is a good-value alternative for simple and continuous dosing tasks. It is especially suitable for water treatment and the process industry.

MAGDOS LB is available for seven capacity ranges. Double-ball valves ensure an accurate dosing. The dosing capacity can be adapted continuously from 0 to 100% through the stroke frequency. You can thus dose with a turn of the wrist.

MAGDOS LB is a compact solution which only includes the most important elements for reliable dosing.

A set of complementary accessories including a tube, an injecting nozzle and a suction line with foot valve from our comprehensive accessories programme allows for a quick installation.

## Wide range of applications

The dosing pump is equipped with a newly designed stroke solenoid. The stroke frequency is adjusted at the dosing pump for different capacities. The pump is externally controlled by switching the supply voltage of the pump ON and OFF.

As a plug & play dosing pump with a wide range power supply unit, it is ready for an immediate and world-wide application without any restriction. For the first time, a new calibration functionality for the adjustment of the capacity by the user is applied.

MAGDOS LB can be mounted on the wall in three different positions - upright, left-oriented or right-oriented - without further auxiliary equipment.

## In short

- Suitable for toxic and aggressive media
- Usable at ambient temperatures of up to 45 °C
- Double-ball valves ensure an accurate dosing
- Dosing capacity continuously adjustable from 0 to 100%
- Wide range power supply unit
- Mounting on wall or floor without bracket
- Calibration functionality



## Model variants

Material	MAGDOS	Connection	Order no.
PVC/FPM	LB 05	4/6	10211014
	LB 1	4/6	10211004
	LB 2	6/9	10211015
	LB 4	6/9	10211005
	LB 6	6/9	10211016
	LB 10	6/9	10211006
	LB 15	6/9	10211017
PP/FPM	LB 05	4/6	10211010
	LB 1	4/6	10211001
	LB 2	6/9	10211011
	LB 4	6/9	10211002
	LB 6	6/9	10211012
	LB 10	6/9	10211003
	LB 15	6/9	10211013
PVDF/FPM	LB 05	4/6	10211018
	LB 1	4/6	10211007
	LB 2	6/9	10211019
	LB 4	6/9	10211008
	LB 6	6/9	10211020
	LB 10	6/9	10211009
	LB 15	6/9	10211021

## Technical data

MAGDOS LB	05	1	2	4	6	10	15
Max. back pressure	16 bar	16 bar	16 bar	16 bar	8 bar	6 bar	3 bar
Flow rate at max. pressure	0.36 l/h	0.76 l/h	1.9 l/h	3.4 l/h	6.2 l/h	9.0 l/h	13.0 l/h
Average back pressure	8 bar	8 bar	8 bar	8 bar	4 bar	3 bar	1 bar
Flow rate at medium pressure	0.54 l/h	1.1 l/h	2.3 l/h	3.8 l/h	6.8 l/h	10.0 l/h	15.0 l/h
Max. stroke frequency	120 min <sup>-1</sup>	250 min <sup>-1</sup>	160 min <sup>-1</sup>	180 min <sup>-1</sup>	180 min <sup>-1</sup>	180 min <sup>-1</sup>	250 min <sup>-1</sup>
Suction lift for non-effervescent media	5 mWS	5 mWS	3 mWS	3 mWS	2 mWS	2 mWS	2 mWS
Max. inlet pressure	800 mbar						
Power supply	110...240 V, 50/60 Hz						
Power supply cable	1.8 m with mains plug						
Power consumption	18 W						
Max. Power consumption during dosing stroke	approx. 4 A						
Protection class	IP 65						
Weight	approx. 3 kg						
Max. ambient temperature	45 °C (with PVC parts 40 °C)						
Max. temperature of the medium	50 °C (with PVC parts 35 °C)						

## Dimensions

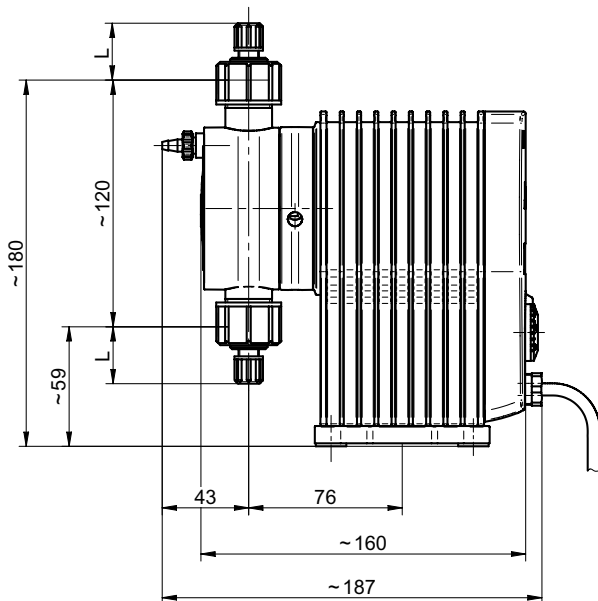

MAGDOS	Tubing connection	Dim. L
LB 05 ... 4	4/6	31 mm
LB 2 ... 15	6/9	34 mm
	6/12	15 mm

All dimensions in mm.

### Performance curves

The performance curves refer to water at 20 °C (68 °F). The performance of the dosing pump depends on the viscosity and the density of the process fluid and hydraulic installation conditions.

Dosing pumps must therefore be gauged in application.

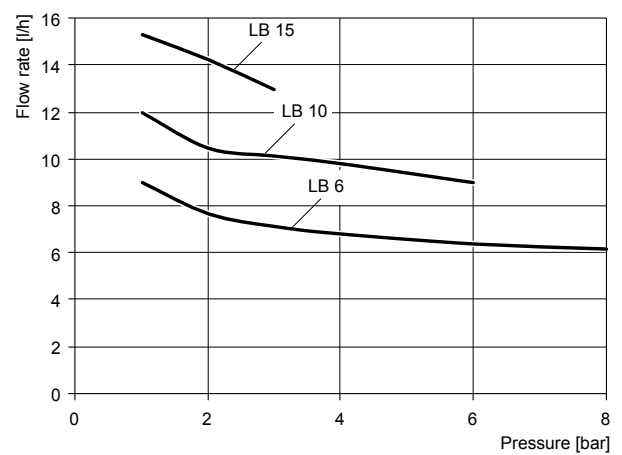
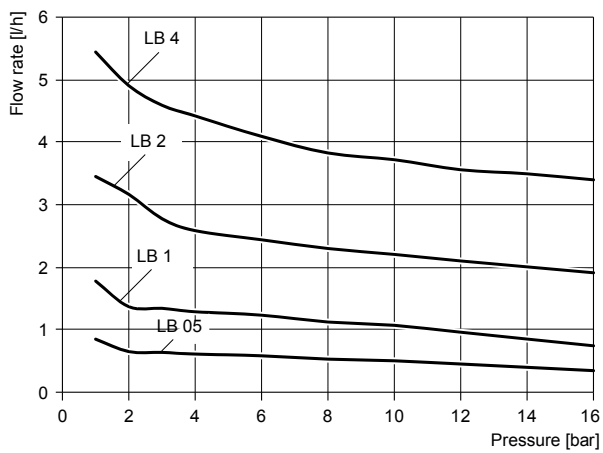

### Installation positions

MAGDOS LB can be mounted in three different positions without further auxiliary equipment:



Floor mounting

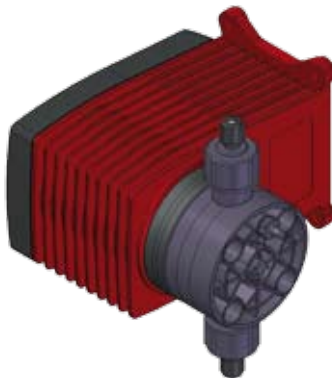

Wall mounting with dosing head on the right-hand side



Wall mounting with dosing head on the left-hand side

# Product Information Solenoid Diaphragm Dosing Pump MAGDOS LB

## Installation examples

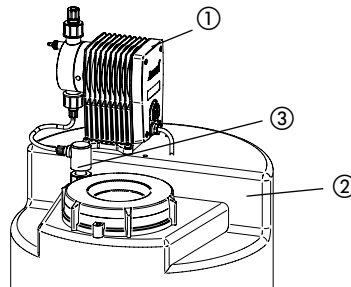
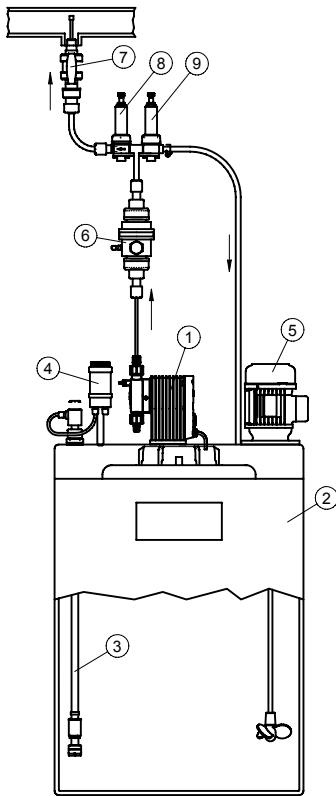

### Legend

- ① MAGDOS LB
- ② Chemical tank
- ③ Suction line
- ④ Priming aid
- ⑤ Electric agitator
- ⑥ Pulsation dampener
- ⑦ Injection nozzle with non-return and shut off valve
- ⑧ Back pressure regulating valve
- ⑨ Pressure relief valve (safety valve)

## Accessories

Suitable sets of accessories, which consist of at least a suction line, a pressure line and an injection nozzle, are available for the dosing pumps.

Even the best dosing pump is capable of improvement - by means of appropriate technical surroundings. That is why a particularly comprehensive accessories programme is available which turns your dosing pump into an efficient dosing system.

For further accessories for your dosing pump, please refer to our dosing pump brochure.

To optimise the dosing process, we recommend back-pressure and pressure-relief valves. They are used

- to increase the dosing accuracy in the presence of fluctuating back pressures.
- for long dosing lines in order to prevent excess delivery. (The accelerated medium continues moving because of its own inertia even when the delivery stroke has already ended.)
- to prevent siphoning through the dosing pump if the suction pressure is higher than the system pressure.
- to prevent the system pressure from rising to an impermissibly high level on the discharge side of the dosing pump; this may for example be caused by the accidental closing of valves while the pump is in operation or a clogged injector.